

# Smart Meter

MR3-D4-WRE&MR3-D4-WE

Multi-function smart meter is a new miniature device with open-type CT access for easy installation, suitable for monitoring the energy consumption of the electrical system. It can also be used for real-time metering of power parameters such as voltage, current, active power, power factor, frequency, and active energy in the line. Finally, it can send the data to the local or remote software platform through WiFi/Ethernet to realize detailed monitoring and analysis of power usage.



## I Applicable Scenarios

- Suitable for European household, small-scale businesses and industrial environments seeking bi-directional metering
- Remote 24-hours real-time monitoring of electricity consumption data, to master the power consumption
- Need to realize local API equipment linkage control and efficient access to HEMS
- Local access to the inverter through the 485 interface to obtain detailed operating parameters, to achieve equipment status monitoring
- Utilizing LoRa technology (configurable) for long-distance data relay transmission to ensure the stability of data transmission
- Need to remotely control the heat pump, with the help of the software platform to regulate its on and off state

## I Features

- LoRa is configurable to realize low power consumption, long-distance data uploading
- Open type transformer, easy to install and maintain
- Compact size, size 2P
- Measurement accuracy active power level 1, reactive power level 2
- Bi-directional metering of electricity consumption or generation data
- It supports data and fault acquisition in millisecond
- Equipped with Bluetooth as standard, supporting local network distribution
- Provides local API interface for efficient access to HEMS
- Conforms to EN 18031 IoT network security standard

# Parameters

Communication Parameters	
Communication Method	WiFi 6, Ethernet, LoRa (Configurable)
WiFi Standard	IEEE 802.11 b/g/n/ax
WiFi Frequency Range	2.412 GHz-2.482 GHz (CH1~CH13)
WiFi Transmit Power	11ax mode HE40:16dBm; 11ax mode HE20:17dBm 11n mode HT40:17dBm; 11n mode HT20:17dBm 11g mode:18dBm 11b mode:18dBm
WiFi Receive Sensitivity	11b,1 Mbps:98dBm; 11b,11 Mbps:90dBm 11g,6 Mbps:93dBm; 11g,54 Mbps:76dBm 11n,HT20 (MCS7):73dBm 11ax,HE20 (MCS9):70dBm; 11ax,HE40 (MCS9):67dBm
Ethernet	1 channel 10/100 Mbps Adaptive
LoRa Operating Frequency (Optional)	863-870 MHz
BLE Wireless Standard	BLE 5.3
BLE Frequency Range	2400 ~ 2483.5MHz
Antenna Type	LoRa external antenna (Configurable), WiFi external antenna

Electrical Characteristics	
Wiring Method	Single-phase 2-wire, 3-phase 4-wire
CT	Default 100A*3 Optional 400A*3
Rated Voltage	230V/400V (±20%)
Input Current	10 (100)A
Rated Frequency	50Hz/60Hz
Operating Power	<4W
Measurement Accuracy	Active power level 1, reactive power level 2

Hardware Parameters	
Communications Interface	RS485*1 (ModbusRTU2400bps~115200bps)
Mounting	DIN Rail 35mm
Operating Temperature	-20°C~+50°C
Operating Humidity	10~70% RH, no condensation
Altitude	Below 2000 meters
Storage Temperature	-20°C~60°C
Storage Humidity	≤40% RH, no condensation
IP Grade	IP20
Flame Retardant Rating	UL 94 V0
Certifications	CE, REACH, RoHS

Software Parameters	
Ethernet Access	≤5 units
Number of Connected LoRa Sub-devices (optional)	Default setting 1 unit (1~10 units optional)
Data Upload Frequency	Default 5 minutes
User Configuration	Local/Remote configuration
Firmware Upgrade	Remote upgrade

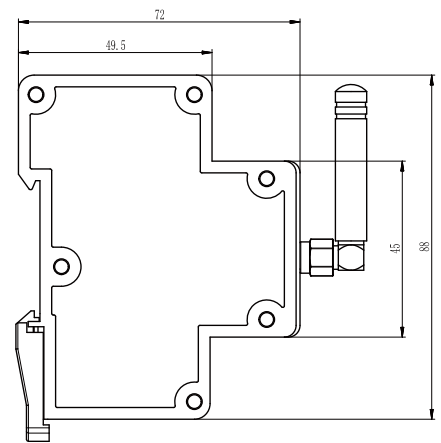
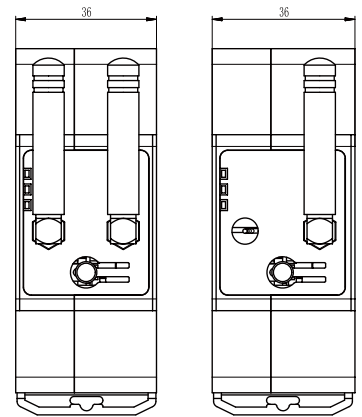

Unit: mm

## IGEN Tech Co., Ltd.

**Add:** Building H4, China IoT International Innovation Park, No. 6, Jingxian Road, Wuxi, Jiangsu, P. R. China

**For Sales:** info@solarmanpv.com **For After-sales:** customerservice@solarmanpv.com

**Whatsapp:** +86 153-1222-5591 **Web:** www.solarmanpv.com